



RAIL-FREE FLUSH ON SHINGLE

Shingle Roof



INSTALLATION MANUAL REV 1.0

Table of Contents/Index:

Item	Page(s)
Notes	3
1. Components	4
2. Racking Installation	4
3. Solar Modules & Module Clamps Installation	5
4. Grounding/Bonding	6
5. General Arrangement drawing.....	7

Notes:

UL2703 verified compatible modules

Modules chosen for UL2703 grounding/bonding testing were chosen to represent a range of available solar modules. Modules tested were from the following manufacturers:

- LG NeON– Model LGxxxN2W-A5
- Jinko Solar – Model JKMxxxM-72L-V, JKM-xxx-M-72-H
- Seraphim SRP-xxx-BMA
- Mission MSE-xxx-SQ8T
- Axitec AC-xxx-MH
- Canadian CS6X-xxx-P

Grounding/Bonding

- Only grounding/bonding devices listed in this manual have been approved for use with this racking and qualified per UL2703 installation details provided in this document
- This racking system may be used to ground and/or mount a PV module complying with UL 1703 only when the specific modules has been evaluated for grounding and/or mounting in compliance with the included instructions.
- Routine maintenance of a module or panel shall not involve breaking or disturbing the bonding path of the system.
- The racking system has a 25 Amp fuse series rating.
- Installer is responsible for and shall provide an appropriate method of direct-to-earth grounding according to the latest edition of the National Electrical Code, including NEC 250: Grounding and Bonding, and NEC 690: Solar Photovoltaic Systems.
- Installation shall be in accordance with CSA C22.1, Safety Standard for Electrical Installations, Canadian Electrical Code, Part 1.

Periodic Inspection

Periodic re-inspection of installed racking components must take place to identify any loose components, loose fasteners or corrosion. Loose or corroded components or fasteners must be replaced immediately.

Fire Rating

****UL1703 FIRE CLASSIFICATION****

This system is not fire rated.

Mechanical Load Design Rating

System Level Allowable Design Load Rating: 35 psf downward, 37 psf upward, 10 psf down-slope.

Each set of site-specific plans must have system loads evaluated and approved by an appropriate structural engineer. This system is designed to be expandable and is not limited by a maximum number of PV modules. Maximum size of PV modules evaluated was 79.7" x 40.3" (i.e. typical 72-cell) and modules are mounted in portrait. A typical modular rail length is approximately 20' (6m) and could hold up to 6 modules.

Label

After the racking system is fully assembled, a single Marking Label should be applied to the rail at the edge of the array. Note: The sticker label should be placed such that it is visible, but not outward facing.

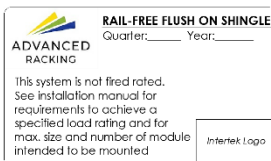

Sharp Edges and Piercing Module Clamps

Ensure wiring is kept away from any sharp edges that may have resulted from cutting rails etc. Module clamps contain pre-installed bonding nodes which are designed to pierce the module frame when tightened to proper torque.

Site-Specific Engineering Drawings

This manual is to be used in conjunction with any site-specific engineering drawings that have been developed for your specific project.

TOOL LIST:

- String Line
- Measuring Tape
- Sharpie
- 13 mm Socket
- Impact Driver

1. Components

Advanced Base

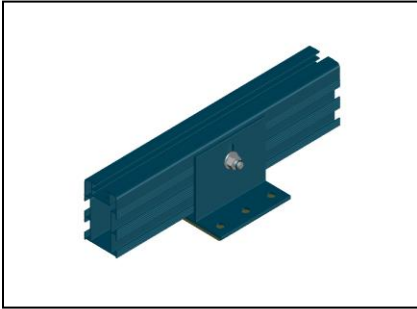

Advanced End Clamp

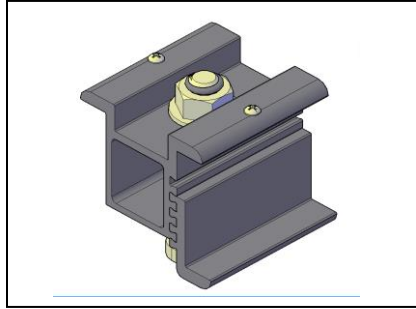

Advanced Mid Clamp

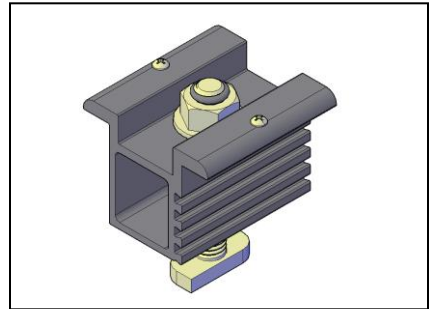

Grounding Lug

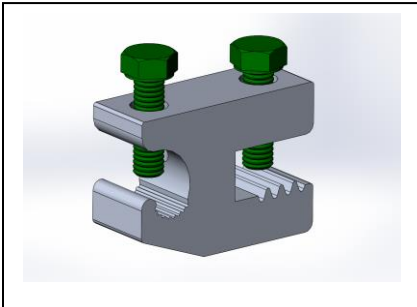

EJOT JT3-2-1/4x2"



GRK RSS Lag Screw 5/16x4"



2. Racking Installation

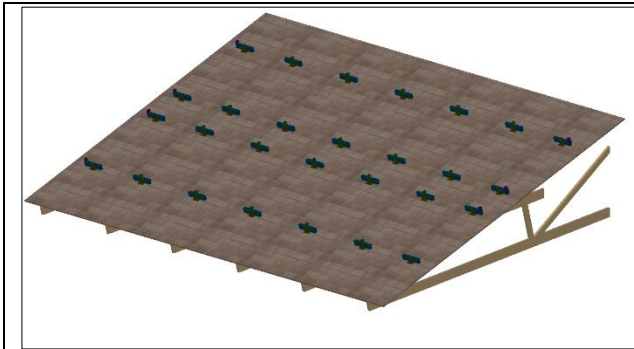

- Use string line to mark the location points for Advanced Bases.
- Advanced Bases must be spaced such as to meet module manufacturer's approved clamping locations.
- Center holes of the advanced base must be positioned above trusses/Rafters.



- Use 8mm or 5/16" hex bit to fasten the Base to the roof using provided EJOT.
- Use 4x EJOT on the non-center holes to fasten the base to the roof deck.
- Use 2x GRK RSS lag screw on the center holes of the base to fasten to the truss
- If a drill is used, start fastening the screw slowly and on the lowest speed setting, then finish by hand to achieve the correct compression as shown in the figure below.

Fasteners with bonded washers should achieve 25% compression to ensure weather seal.

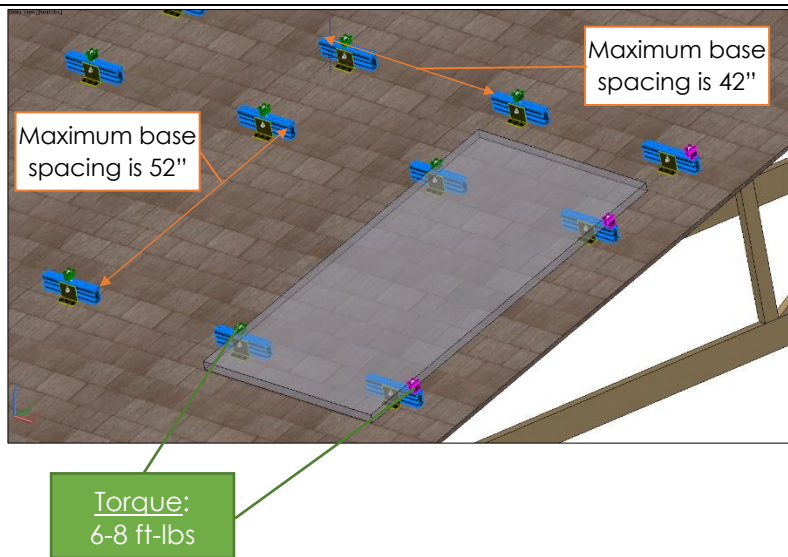
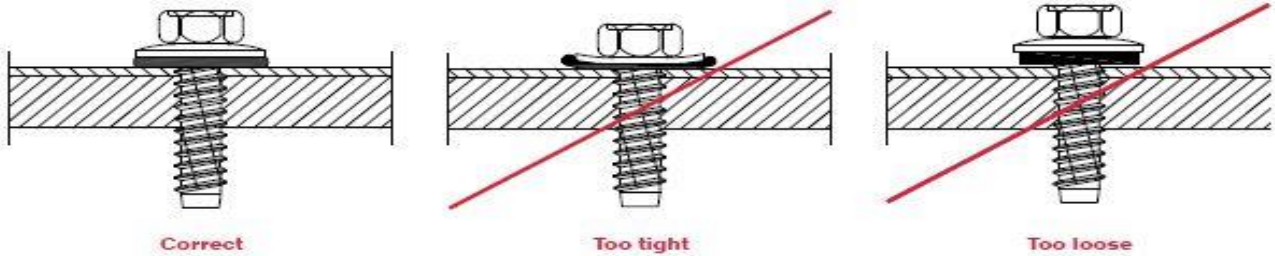

- Place module end clamp into rail by inserting the T bolt into base rail's top channel. Tighten once clamp is flush with module
- Once module end clamp is secure and module in place, insert the mid clamp into the rail flush against module
- Mounting location of ends clamps is to be in the middle of base.
- Confirm modules are flush with clamps. Taking time/care in getting the first PV module square, following modules line up more easily
- Consult module and rail layout when placing the first module.

4. Grounding / Bonding

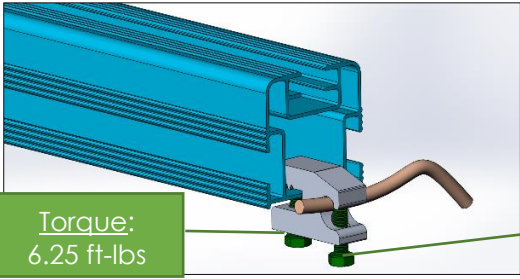

- As per diagram below, use SGB-4 to bond one rail per row of modules using #6 copper wire. System grounding must be in accordance with the National Electrical Code, ANSI/NFPA 70.

Torque: 6.25 ft-lbs

Torque: 2.9 ft-lbs

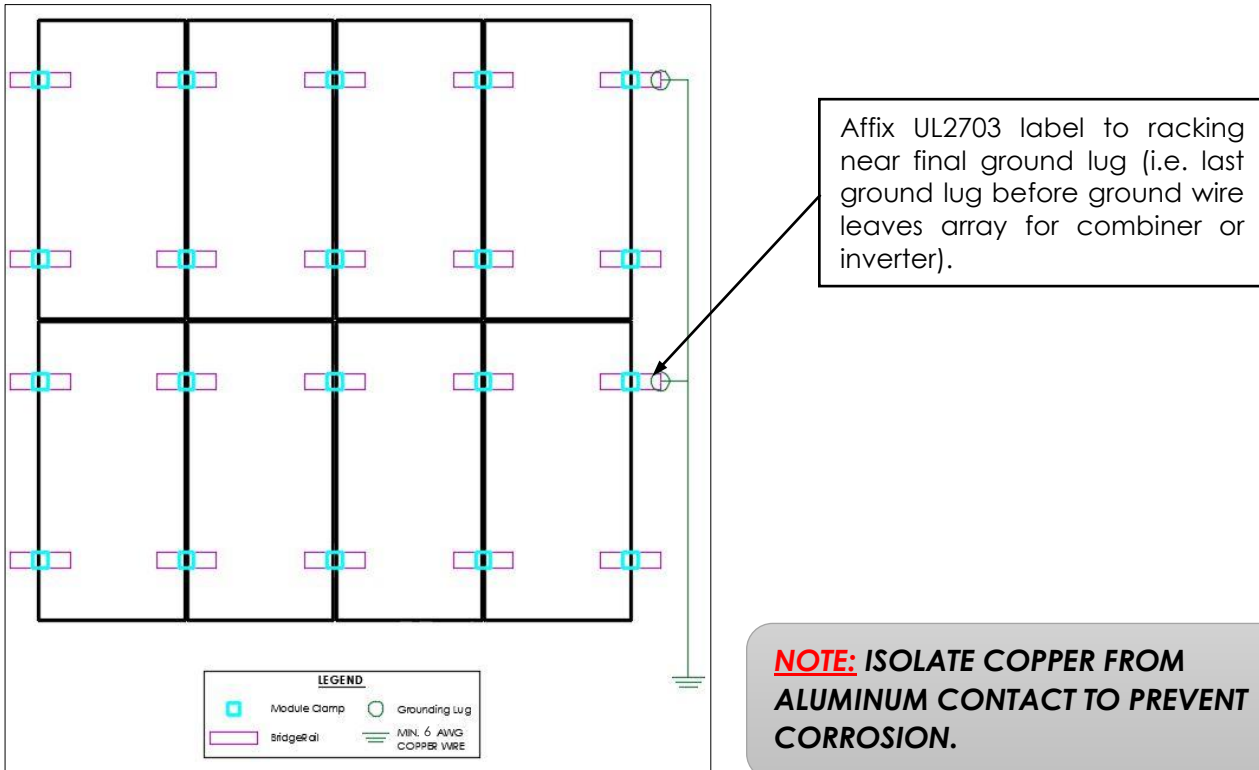

NOTE: ISOLATE COPPER FROM ALUMINUM CONTACT TO PREVENT CORROSION.

NOTE: AFFIX UL2703 LABEL TO THE RACKING IN A VISIBLE LOCATION NEAR THE GROUND LUG AT FINAL BONDING LOCATION.

5. General Arrangement Drawings

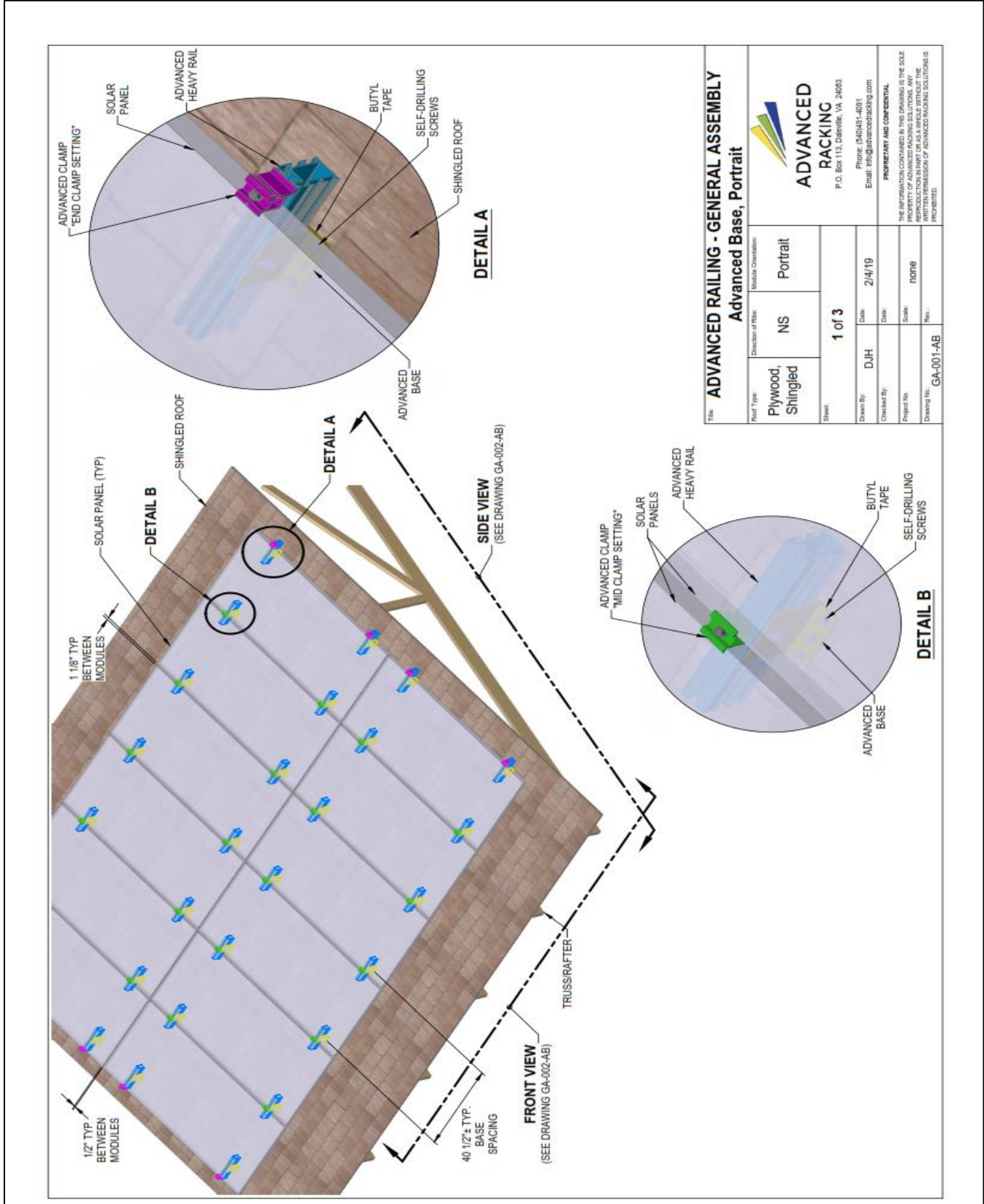

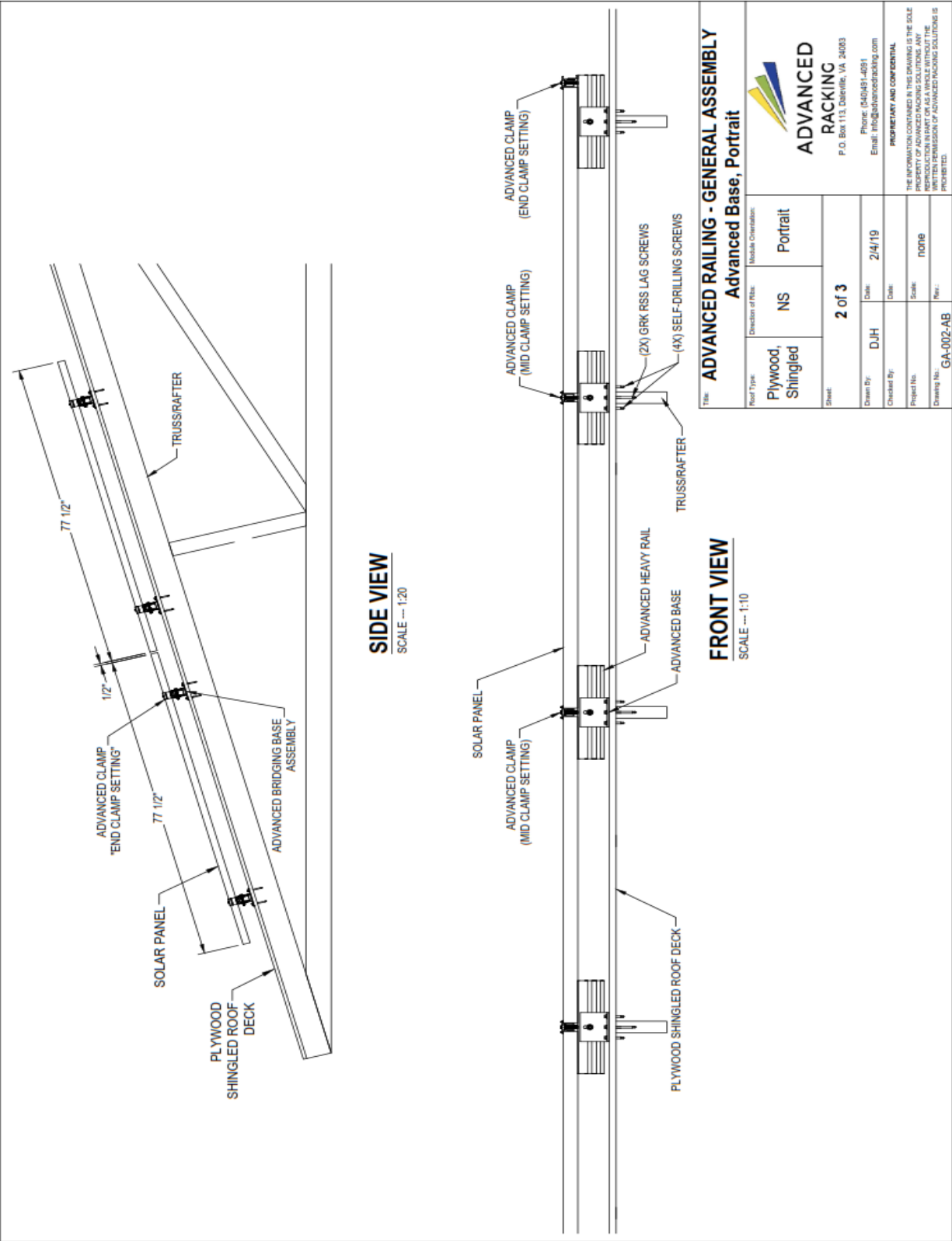

Title: ADVANCED RAILING - GENERAL ASSEMBLY
Advanced Base, Portrait

Roof Type: Plywood, Shingled	Direction of Rise: NS	Module Orientation: Portrait
Sheet: 2 of 3	Drawn By: D.J.H.	Date: 2/4/19
	Checked By:	Date:
	Project No.:	Scale: NONE
Drawing No.:	GA-002-AB	Rev.:

Phone: (800)991-4951
Email: info@advancedracking.com
PROPRIETARY AND CONFIDENTIAL
THE INFORMATION CONTAINED IN THIS DRAWING IS THE SOLE PROPERTY OF ADVANCED RACKING SOLUTIONS. ANY REPRODUCTION IN PART OR AS A WHOLE WITHOUT THE WRITTEN PERMISSION OF ADVANCED RACKING SOLUTIONS IS PROHIBITED.